

FIXING TRESPA® METEON®

Trespa® Meteon® brings compelling aesthetic and nearly limitless design possibilities to next-generation architectural claddings. Use Trespa® Meteon® on its own, or in combination with other materials, to create stunning façades or highlights.

To suit your special requirements, Trespa® Meteon® can be applied in a number of ways, using a variety of joinery details and fixing methods. Choice of fixings and availability per country is dependent on relevant building codes and national certifications. For information on possible fixing systems in your region and more detailed technical information, visit www.trespa.info

The following fixing methods are available:

- > Invisible Fixing (Concealed Fixing)
- > Visible Fixing (Exposed Fixing)
- > Deep Cavity (Insulated) Fixing
- > Special Fixing
- > Adhesive Fixing

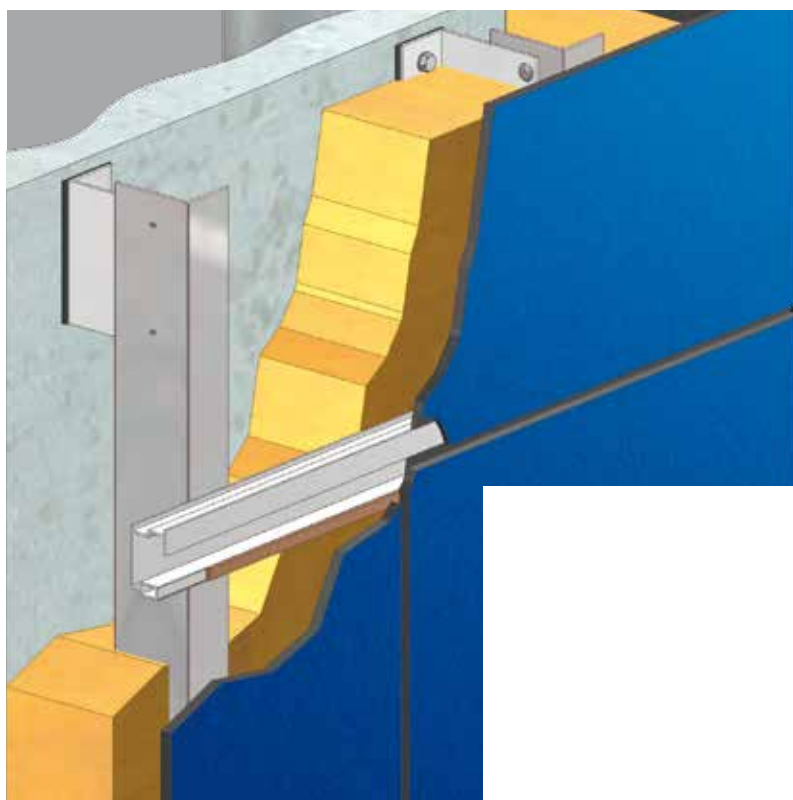

GENERAL INSTALLATION GUIDELINES

In this document an overview of principles for fastening facade cladding is shown. These principles are generic and represent the state of the art. In cases where national standards do not directly link with the current building codes, special certificates can bridge this gap. Such certificates refer to facade cladding products as well as to fasteners or fixing elements in particular. Certificates are issued to the party that sells the most significant part of the fixing method. Both manufacturers as well as agents of the products in particular can hold a certificate. In cases where there are no specific standards, nor are there specific building codes or certificates, the local building authorities need to evaluate if the proposed fixing method does comply with the current regulations.

Due to the nature of the product Trespa® Meteon® and its application as drained and back-ventilated rain screen cladding and unrelated to any fixing method, there are 3 topics that need special attention:

- 1. Ventilation.** The facade cladding needs to be ventilated at the rear of the panel to release migrated water vapour from the ambient rooms and to dry condensation at the inner parts of the wall construction. This requires a certain ventilation cavity depth and a certain dimension of the ventilation inlets and outlets.
- 2. Tension-free fastening.** The facade cladding needs to be able to expand and shrink independently from its load-bearing sub-frame due to heat and moisture influences. This requires a certain free space in the fastening for movements. Also limitations in the maximum panel size as well as minimum dimensions of the joints in between panels and between panels and other construction parts are a result of this requirement.
- 3. Sub-frame.** Trespa® Meteon® panels must be installed on a sub-frame of sufficient strength and permanent durability. Quality and/or treatment of the sub-frame must be in accordance with certificate holders' recommendations as well as applicable building standards and regulations.

Although most fixing methods are generic, there might be differences in the details as stated in national certificates. Such differences occur due to country specific building traditions; differences in national standards or different rules and assumptions for detailed calculations.

Following fixing methods are recognized by Trespa:

- Invisible fixing
- Visible fixing
- Deep cavity fixing
- Special fixing

Invisible fixing

Trespa can be invisibly (i.e. concealed) fixed by using mechanically fastened metal brackets at the rear of the panels in combination with horizontal metal rails, or by

machining profiled edges in the panels in combination with metal rails or clamps. System descriptions, CAD-details and certificates can be found at www.trespa.info

Invisible Fixing (Concealed Fixing)

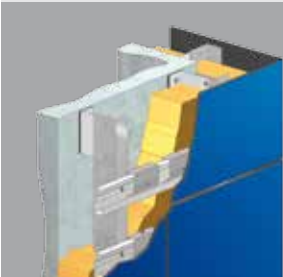
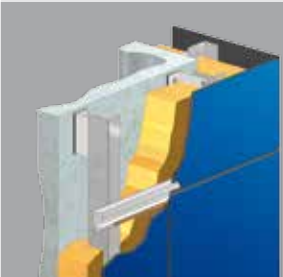
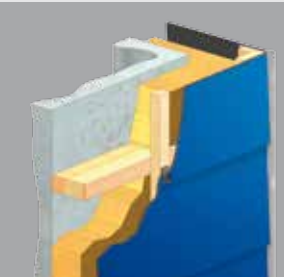
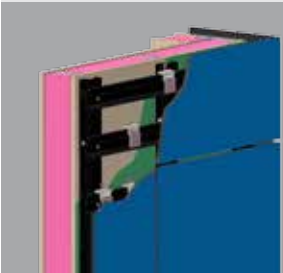
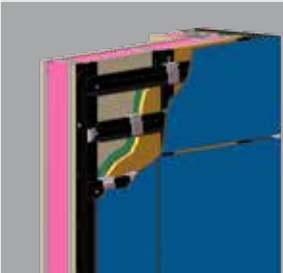
TS200 Invisible (concealed) fixing with brackets on rails	TS300 Invisible (concealed) fixing using profiled edges	TS600/650 Invisible (concealed) fixing of sidings
		
TS210 Invisible (concealed) bracket-railfix on an aluminium sub-frame	TS210-285 Invisible (concealed) bracket-railfix on an aluminium sub-frame	
		

Visible fixing

Trespa® Meteon® can be visibly (i.e. exposed) fixed by using screws and a timber sub-frame or using rivets or

screws on a metal sub-frame. System descriptions, CAD-details and certificates can be found at www.trespa.info

Visible Fixing (Exposed Fixing)

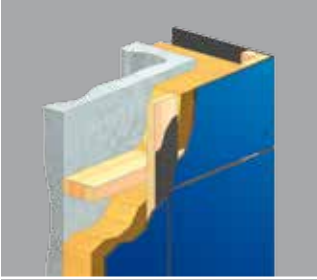
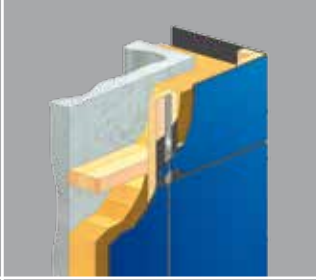
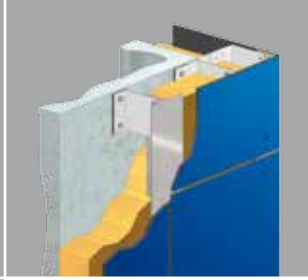
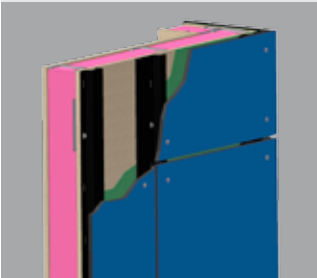
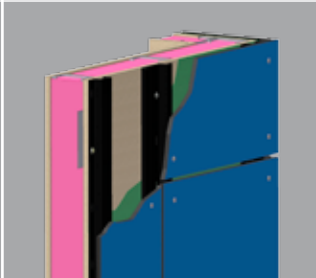
TS150	TS550	TS700
Visible (exposed) fixing with screws on a timber sub-frame	Semi – visible (exposed) fixing with metal tongues on a timber sub-frame	Visible (exposed) fixing with rivets on a metal sub-frame
		
TS110	TS110-285	
Visible (exposed) fixing with screws on an aluminium sub-frame	Visible (exposed) fixing with screws on an aluminium sub-frame	
		

Deep cavity fixing

In order to allow for thicker insulation packages in combination with metal-stud load-bearing walls, extensions for metal sub-frames are available for both exposed as well as concealed fastening.

Special fixing

For high rise buildings a metal sub-frame is developed to span from floor to floor including fire barriers at each floor. This fixing method is predominantly used for visible fixing with rivets. System descriptions, CAD-details and certificates can be found at www.trespa.info

Deep Cavity (Insulated) Fixing

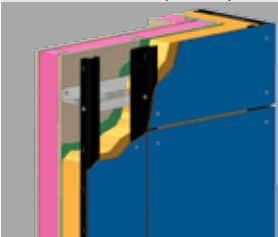
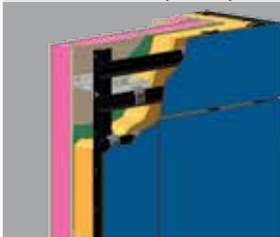
TS110DC-285/TS110-134	TS210DC-285/TS210-134
Visible (exposed) fixing with screws on an aluminium sub-frame – deep cavity	Invisible (concealed) bracket-railfix on an aluminium sub-frame – deep cavity
	

Special Fixing

System 700
Visible (exposed) fixing with rivets on a specific aluminium sub-frame (span from floor to floor)

Country

Fixing System	Netherlands	Belgium & Luxembourg	France	United Kingdom	Germany	Italy	Spain	China	USA	Canada	Mexico	Chile
Invisible Fixing (Concealed Fixing)												
TS200	■	■	■	■	■	□	■	□				□
TS210									■	□	□	
TS210-285									■			
TS300	■	■	■	□	■	□	■	□				□
TS600/650	■	■	■	□	□	□	■	□				□
Visible Fixing (Exposed Fixing)												
TS110									■	□	□	
TS110-285									■			
TS150	■	■	■	■	■	□	■					
TS550	■						■					
TS700	■	■	■	■	■	□	■	□			□	□
Deep Cavity (Insulated) Fixing												
TS110-134										□		
TS110DC-285									■			
TS210-134										□		
TS210DC-285									■			
Special Fixing												
System 700				■								

- fixing methods certified for Trespa® Meteon® facade cladding and commonly used by Trespa customers
- fixing methods commonly used by Trespa customers¹

The aforementioned fixing methods are widely accepted in the countries in which Trespa International is represented with their own sales team. The table above shows fixing methods commonly used by Trespa customers in various

countries and in which countries Trespa holds a certificate for a particular fixing method in particular and thus special fixing accessories are available.

Adhesive fixing

Finally there are also fixing methods that have a limited geographical acceptance. These fixing methods are based on elastic adhesives that fasten the cladding panels to a timber or metal load-bearing sub-frame. Country specific

certificates are issued to the manufacturer or agent of the adhesive system. The design and installation guidelines of the adhesive supplier are imperative.

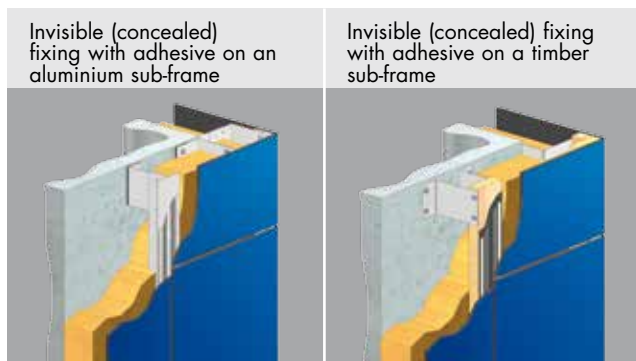

Although the majority of past Trespa installations have been mechanically fixed, the use of adhesive fixing systems is possible under certain conditions, including careful attention to various installation details, installation by a qualified party in accordance with all guidelines and recommendations of a qualified adhesive manufacturer, and in compliance with all applicable codes. Trespa is not responsible for the selection or use of adhesives in fixing systems.

Always up to date, think www.trespa.info

The website www.trespa.info offers you a complete overview of all technical product information, CAD drawings and certification online. This website is kept updated at all times, so you can be sure to find exactly what you need, whenever you need it, easily and quickly.

Finding the information you need has never been this easy:

- Up-to-date, at all times.
- Easy-to-use: all information clearly laid out.

Please visit www.trespa.info and find all the information you need.

Disclaimer¹

Not all certification required for your project may be available through Trespa or additional certification may have to be obtained by the customer. Therefore, also in relation to the above overview, Trespa strongly advises that the customer, project owner and architect seek independent advice from a construction professional regarding the accordance to national and/or local building regulations of a chosen fixing system.

This is a print generated by you from www.trespa.info ("Website"). By accessing the Website and printing this document you have accepted the Terms of Use of the Website. Please refer to the Website for all conditions that apply to this document. Not all the systems shown in this document may be suitable for all applications and jurisdictions. We provide you with testing, code and design data for informational purposes only and strongly recommend that you or any other user of this document obtains independent advice regarding compliance with design requirements, applicable codes, laws and regulations, and test standards. Please check your local codes and design requirements for proper use. Trespa will not accept any liability in relation to your use of this document.

All intellectual property rights, including copyrights and other rights regarding the content of the Website and this print generated from the Website (including logos, trademarks, service marks, software, databases, audio, video, text and photographs) are owned by Trespa and/or its licensors. Trespa®, Meteon®, Athlon®, TopLab®, TopLab^{PLUS}®, TopLab^{ECO-FIBRE}®, Virtuton®, Volkern®, Trespa Essentials® and Mystic Metallics® are registered trademarks of Trespa.

All oral and written statements, offers, quotations, sales, supplies, deliveries and/or agreements and all related activities of Trespa are governed by the Trespa General Terms and Conditions of Sale (Algemene verkoopvoorwaarden Trespa International B.V.) filed with the Chamber of Commerce and Industry for Noord- en Midden- Limburg in Venlo (NL) on 11 April 2007 under number 24270677, which can be found on and downloaded from the Trespa website, www.trespa.com/documentation.

All oral and written statements, offers, quotations, sales, supplies, deliveries and/or agreements and all related work of Trespa North America, Ltd. are governed by the Trespa North America General Terms and Conditions of Sale, which can be found on and downloaded from the Trespa website, www.trespa.com/documentation. A copy of these general conditions of sale will be provided free of charge on request.