



PURA® NFC

BY TRESPA

INSTALLATION MANUAL

SIDINGS

PURA-NFC.COM

TRESPA®

FOREWORD

INSTALLATION MANUAL FOR THE PROFESSIONAL INSTALLER

Dear customer,

Congratulations on your purchase of this Pura® NFC product. These instructions contain all the necessary information in order to quickly achieve a professional result.

This Pura® NFC constitutes part of the Pura® NFC siding System. These instructions describe how you can use the Pura® NFC siding System. The other components which constitute part of the Pura® NFC siding System must be purchased separately. There is a summary of the components in Chapter 1.

The information in these instructions is important for the proper and safe use of the product. We kindly request you to go through this information carefully, before you start to work with the product.

Keep these instructions.

INTENDED USE

Pura® NFC is intended to coat façades.
Pura® NFC is intended for the professional processor.

The user must be aware of the local building regulations.
For current product/technical information see www.trespa.info.

WARNING

Any use other than the intended use described above is considered unintended use.

This document is intended to provide general recommendations only. Trespa provides these guidelines and all testing, code and design data for informational purposes only and strongly advises that the customer, project owner and architect seek independent advice from a certified construction professional and/or engineer regarding application and installation as well as compliance with design requirements, applicable codes, laws and regulations, and test standards. Please check your local codes and applicable design requirements for proper use.

SYMBOLS IN THE INSTRUCTIONS

Safety symbols:

WARNING

In some cases the users may (seriously) injure themselves or seriously damage the product. A warning indicates what damage may occur if the user does not carry out the procedure carefully.

CAUTION

The product may be at risk. 'Caution' indicates damage to the product if the user does not perform the procedures carefully.

NOTICE

This is a comment with additional information for the user. A comment alerts the user to potential problems.

CONTENTS

Foreword	3
Intended use	3
Symbols in the instructions	3
Important terms in these instructions used in an overview	4
Get results in four simple steps - Horizontal installation	5
1 Ensure the correct supplies.	5
2 Make a façade drawing.	8
3 Ensure the correct basic construction.	8
4 Carry out the installation instructions.	8
Finishing around a window	
What should I look for when I place Pura® NFC siding around a window?	11
Vertical Installation	
What should I look for when I place Pura® NFC siding vertically?	11
Illustrations	12

IMPORTANT TERMS IN THESE INSTRUCTIONS USED IN AN OVERVIEW

SEE **IMAGE 1** Overview drawing Pura® NFC siding System.

- A Vertical batten
 - B Building paper (if applicable)
 - C Siding
 - D Intermediate joint
 - E Finish profile
 - F Start joint / finish joint
 - G Outer-corner profile
-

GET RESULTS IN FOUR SIMPLE STEPS

YOU CAN EQUIP YOUR FAÇADE WITH PURA® NFC SIDING IN FOUR EASY STEPS:

- 1 Ensure the correct supplies.
- 2 Make a façade drawing.
- 3 Ensure the correct basic construction.
- 4 Carry out the installation instructions.

1 ENSURE THE CORRECT SUPPLIES

Pura® NFC System Components

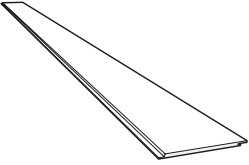
Pura® NFC siding	
	Dimensions (mm)
	3050 x 186 x 8
Siding	

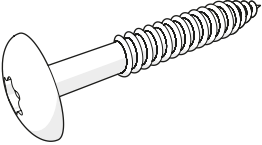
SFS HPL fast fixing screw	
	Dimensions (mm)
	4.8 x 38
HPL fast fixing screw	

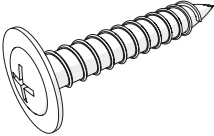
SFS profile screw	
	Dimensions (mm)
	4.1 x 30
SFS profile screw	

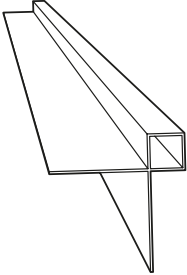
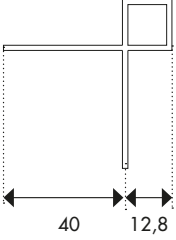
Proface® Outer-corner profile	
	Dimensions (mm)
	Length 3000 
Outer-corner profile	

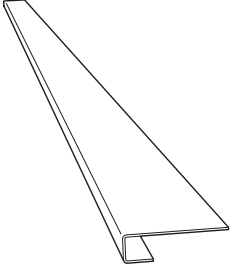
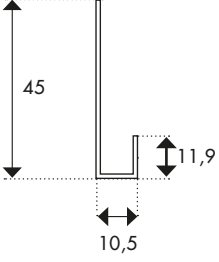
Proface® finish profile	
	Dimensions (mm)
	Length 3000 
Finish profile	

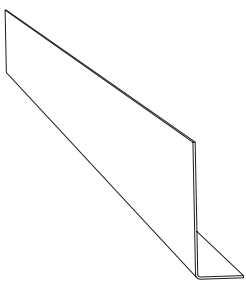
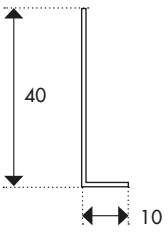
Proface® support profile	
	Dimensions (mm)
	Length 3000 
Support profile	

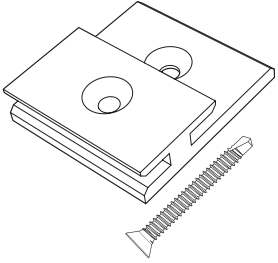
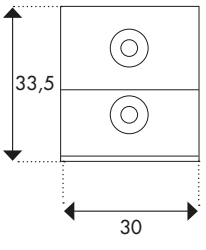
Universal clips (including matching screws)	
	Dimensions (mm)
	33.5 x 30 x 7.6 
Universal clip	

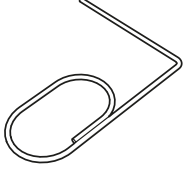
Positioning tool set

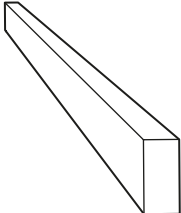
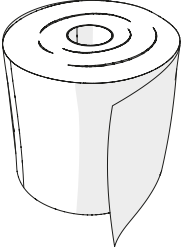
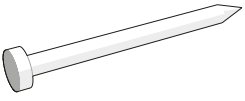
Positioning tool set

Materials		
		
Installation bar	EPDM rubber. At least the width of the vertical battens	Flat head nails to fix the mounting bar and fix the siding

ENGLISH UK

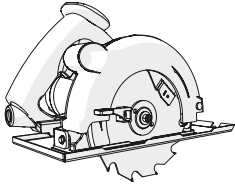
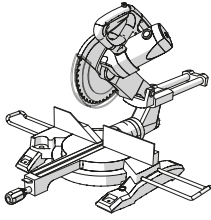
Tools



The following general guidelines apply when sawing Pura® NFC Sidings:

- **Tooth:** Alternate tooth or trapezoid flat tooth.
 - **Positioning:** Always position the entering tooth at the decorative side of the Pura® NFC Siding.
 - **Cutting edges:** Any sharp edges can be removed using sandpaper or a router.
 - **Rake angle:** A rake angle of 45° gives the best performance.
- ➔ For current information regarding Trespa's machining guidelines see www.trespa.info.

Short saw or circular saw

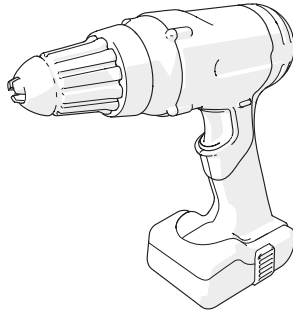

Cordless screwdriver / drill with torque limiting coupling



Carbide-tipped HSS drill, top angle 60-80°. Pura® NFC Sidings should be drilled with support sheets.

- ➔ For current information regarding Trespa's machining guidelines see www.trespa.info.



Diameter in mm	No. of revolutions	Feed rate in mm/min
5	= 3000/min	60-120
8	= 2000/min	40-80

Hard metals - HSS drill

2 MAKE A FAÇADE DRAWING

Points for attention when creating the façade drawing:

- Intermediate joints are located in the middle of the vertical battens.
- The width of the intermediate joint must be 8 mm.
- The sidings must overlap by 6.5 mm after mounting.
- The maximum distance between the vertical battens is 600 mm on center.
- The vertical battens must be 95-110 mm wide.
- At outer corners use outer-corner profiles.
- The distance between the sidings and a outer-corner profile (the end joint) must be 5 mm.
- Is there an interruption (window, door, etc.) in the façade? If so, then make sure the sidings are not sawn too small. You can influence this by adjusting the starting height (H).

SEE FIGURE 2 Before you begin, make a plan in the form of a façade drawing

SEE FIGURE 3 The end profiles must be at least 5 mm wide

3 ENSURING THE CORRECT BASIC CONSTRUCTION

Points for attention for the basic construction

- Pura® NFC can be used as part of a ventilated façade system which allows air circulation between the façade material and the water resistant layer behind it.
- To ensure natural ventilation, the façade is installed with a cavity of at least 20 mm deep behind the façade material.
- Install vertical battens, spaced no more than 600 mm apart.
- At the bottom and top of the cladding, as well as at each interruption in the façade (e.g. window frames), ventilation spaces should be made of at least 50cm²/m¹.
- Finish, if required, the ventilation spaces with a ventilation profile.
- Ensure a suitable corner construction.

SEE FIGURE 4 Ensure proper base construction

4 CARRY OUT THE INSTALLATION INSTRUCTIONS

1. Apply strips of EPDM rubber

Use a strip of EPDM rubber which is at least as wide as the vertical batten.

SEE FIGURE 5 Apply strips of EPDM rubber

2. Place the outer-corner profiles and finish profiles (if they appear in your façade drawing)

SEE FIGURE 6 Place the outer corner profiles and finish profiles

3. Install an installation bar

Install an installation bar at a distance of 35 mm from the starting height. You use the installation bar as attachment points for the first row of universal clips.

SEE **FIGURE 7** | Install an installation bar

4. Place the first row of universal clips

- Place the first row of universal clips with the installation head down.
- Screw the universal clips into the top hole.
- Do you plan to equip the first row of sidings with an intermediate joint?
If so, then place two universal clips.
- Do not place the clip on a finishing profile.

SEE **FIGURE 8** | Place the first row of universal clips

SEE **FIGURE 9** | Place two universal clips where you want to make an intermediate joint

5. Saw the sidings to size

Saw the sidings with their decorative side facing up.

🔗 For current information regarding Trespa's machining guidelines see www.trespa.info.

SEE **FIGURE 10** | Saw the sidings to size

6. Place the bottom row of sidings

- Remove the installation bar.
- Place the sidings by sliding them from the top of the universal clips.

SEE **FIGURE 11** | Place the bottom row of universal clips

7. Install the second row of universal clips

- Place the universal clips with the installation head facing up.
- Screw the universal clips into the top hole.
- Check that the intermediate joint is at least 8 mm wide.
- Use the positioning tool set provided to allow 1 mm vertical expansion.
- Do you plan to equip the next row of sidings with an intermediate joint?
If so, then place two universal clips at the position of the joint.

SEE **FIGURE 12** | Place the second row of universal clips and screw them in. Use the positioning tool set provided for this.

8. Fix every siding with a flat head nail

- Drill one hole of 2 mm in the thin part of each siding.
- Fix every length piece of siding with a flat head nail.

SEE **FIGURE 13** | Fix the façade strip with a flat head nail

9. Place the second row of sidings

- When placing a row of sidings always check that an intermediate joint is supported on both sides by its own universal clip.
- Check that the intermediate joint is at least 8 mm wide.
- Fix every siding with a flat head nail.

SEE **FIGURE 14** When placing a row of sidings check the support of the intermediate joint

10. Install the other row of sidings

Install the other row of sidings from below to above.

SEE **FIGURE 15** Install the other row of sidings from below to above

11. Place the last row of sidings

Finish with universal clips if you have enough space.

Not enough space?

- Saw the top row of sidings to size.
- Drill 8 mm holes.

NOTICE

Drill holes at 20 mm from the top of the siding, at least 20 mm from the side of the vertical batten, and at least 20 mm from the end of the siding.

- Tip: drill one of the holes 5 mm. You fix the siding here.
- Fix the siding with the fast fixing screws. Place an installation ring of 3 mm between the vertical batten and the siding.

SEE **FIGURE 16** Finish with universal clips if you have enough space

SEE **FIGURE 17** Don't have enough space? Saw the bottom row of sidings to size

SEE **FIGURE 18** If you have sawn off the sidings, drill 8 mm holes

SEE **FIGURE 19** Install with HPL Fast fixing screws. Place an installation ring between the siding

SEE **FIGURE 20** Place a 3 mm installation ring between the siding and the vertical batten

12. Ensuring the correct finishing

Ensure the correct finishing. For example, use a roof trim to cover the top row of universal clips (or HPL fast fixing screws).

SEE **FIGURE 21** Finish with, for example, a roof trim

ENGLISH UK

FINISHING AROUND A WINDOW

WHAT SHOULD I LOOK FOR WHEN I PLACE PURA® NFC AROUND A WINDOW?

- Support the siding directly above the window with a support profile (A).
- Finish the side of the window with a finish profile (B1) or a outer-corner profile (B2).
- Finish the underside of the window with a weather moulding (C).

SEE **FIGURE 22** Finishing around a window

FINISHING AROUND A DORMER

WHAT SHOULD I LOOK FOR WHEN I PLACE PURA® NFC SIDINGS AROUND A DORMER?

- Fix the bottom siding with a fast fixing screw.

SEE **FIGURE 23** Finishing on a dormer

VERTICAL INSTALLATION

WHAT SHOULD I LOOK FOR WHEN I PLACE PURA® NFC VERTICALLY?

- Place horizontal battens placed 600 mm apart and ensure sufficient ventilation space behind the horizontal battens to allow for natural ventilation
- Apply strips of EPDM rubber on the horizontal battens
- Mount the siding vertically on the horizontal battens, supported by the Proface® support profile.
- In case of an inner joint:
 - Ensure the joint in the middle of the horizontal batten, allowing sufficient space for the fixing clip below and above the joint.
 - Cut the support profile to 100 mm length.
 - Place the profile with 8 mm joint above the siding underneath.
- Saw the last siding vertically to size; drill 8mm holes at least 20 mm from the top of the siding, 20 mm from the side of the siding/horizontal batten; fix the siding with fast fixing screws.

SEE **FIGURE 24+25** Vertical Installation

DISCLAIMER**GENERAL**

These terms apply to the use of this document and such use automatically means that the other party agrees to these terms. The information provided by Trespa International B.V. ("Trespa") in this document is solely indicative. Trespa is unable to warrant the accuracy and completeness of this information. Trespa may change the information included in this document at any time and without further notice. Trespa's customers and third parties must ascertain that they have the most recent document (for the most recent version, please consult: www.trespa.com). No rights can be derived from the information provided; the use of the information is at the other party's risk and responsibility. Trespa does not warrant that the information in this document is suitable for the purpose for which it is consulted by the other party. This document does not contain any design, structural calculation, estimate or other warranty or representation that customers and third parties may rely on. This document does not guarantee any properties of Trespa products. Colours used in Trespa's communications (including but not limited to printed matter) and in samples of Trespa's products may differ from the colours of the Trespa products to be supplied. Samples are not intended for use in product tests and are not representative of characteristics of the Trespa products. Trespa's products and samples are produced within the specified colour tolerances and the colours (of production batches) may differ, even if the same colour is used. The viewing angle also influences the colour perception. Metallic panels feature a surface whose colour appears to change based on the direction from which it is viewed. The specified colour stability and colour specifications relate only to the decorative surface of the Trespa products, not to the core material

and samples of the Trespa products. Trespa products are delivered ex-works with straight, sawn sides. Customers and third parties must have a professional adviser inform them about (the suitability of) the Trespa products for all desired applications and about applicable laws and regulations. Trespa does not warrant the above. The most recent version of the current delivery programme and the Material Properties Datasheet can be found at www.trespa.info. Only the information in the most recent and valid Material Property Datasheet should be used to select and provide advice regarding Trespa products. Trespa reserves the right to change (the specifications for) its products without prior notice.

LIABILITY

Trespa is not liable (neither contractual nor non-contractual) for any damage arising from or related to the use of this document, except if and to the extent that such damage is the result of wilful misconduct or gross negligence on the part of Trespa and/or its management. The limitation of liability applies to all parties affiliated with Trespa, including but not limited to its officers, directors, employees, affiliated enterprises, suppliers, distributors, agents, and representatives.

GENERAL CONDITIONS

All oral and written statements, offers, quotations, sales, supplies, deliveries and/or agreements and all related activities of Trespa are governed by the Trespa General Terms and Conditions of Sale (*Algemene verkoopvoorwaarden Trespa International B.V.*) filed with the Chamber of Commerce and Industry for Noord- en Midden- Limburg in Venlo (NL) on February 20th, 2015 under number 24270677, which can be found on and downloaded from the Trespa website,

www.trespa.com/documentation. All oral and written statements, offers, quotations, sales, supplies, deliveries and/or agreements and all related work of Trespa North America, Ltd. are governed by the Trespa North America General Terms and Conditions of Sale, which can be found on and downloaded from the Trespa website, www.trespa.com/documentation. A copy of these general conditions of sale will be provided free of charge on request. All general terms and conditions other than the conditions mentioned above are dismissed and do not apply, regardless of whether such terms and conditions are referred to on requests for offers, offer confirmations, stationery and/or other documents of the other party, even if Trespa does not expressly object to such terms and conditions.

INTELLECTUAL PROPERTY

All intellectual property rights and other rights regarding the content of this document (including logos, text and photographs) are owned by Trespa and/or its licensors. Any use of the content of this document, including distribution, reproduction, disclosure, storage in an automated data file or the dispatch of such a file without Trespa's prior written consent is explicitly prohibited. * Trespa, Meteon, Athlon, TopLab, TopLab^{VELIS}, TopLab^{ECO-FIBRE}, TopLab^{VERTICAL}, TopLab^{BASE}, Virtuon, Izeon, Pura, Pura NFC, Volkern, Trespa Essentials and Mystic Metallics are registered trademarks of Trespa.

QUESTIONS

Should you have any questions or comments, please do not hesitate to contact Trespa.

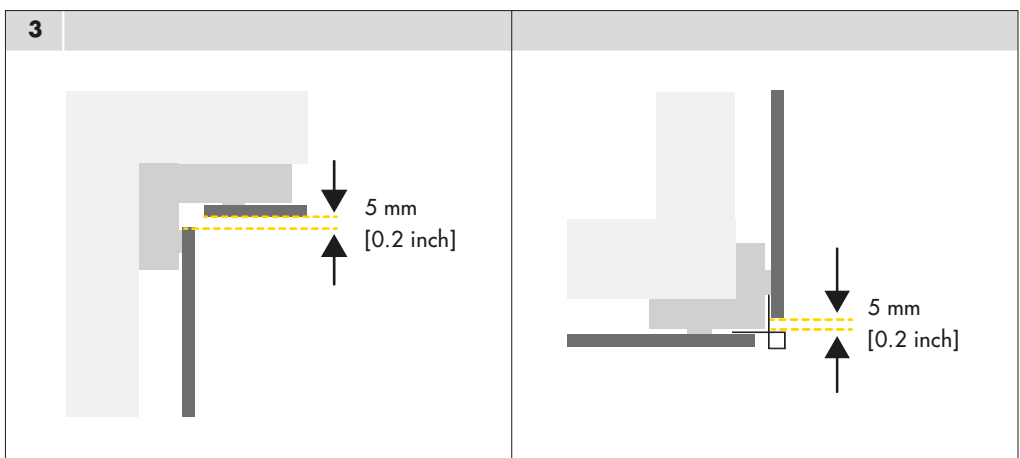
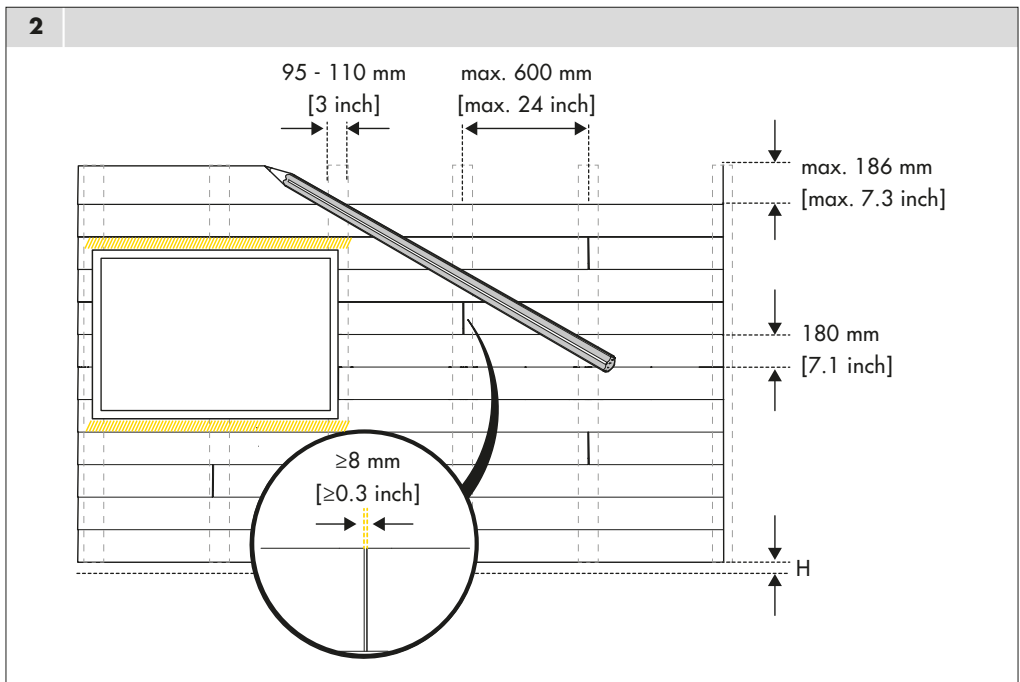
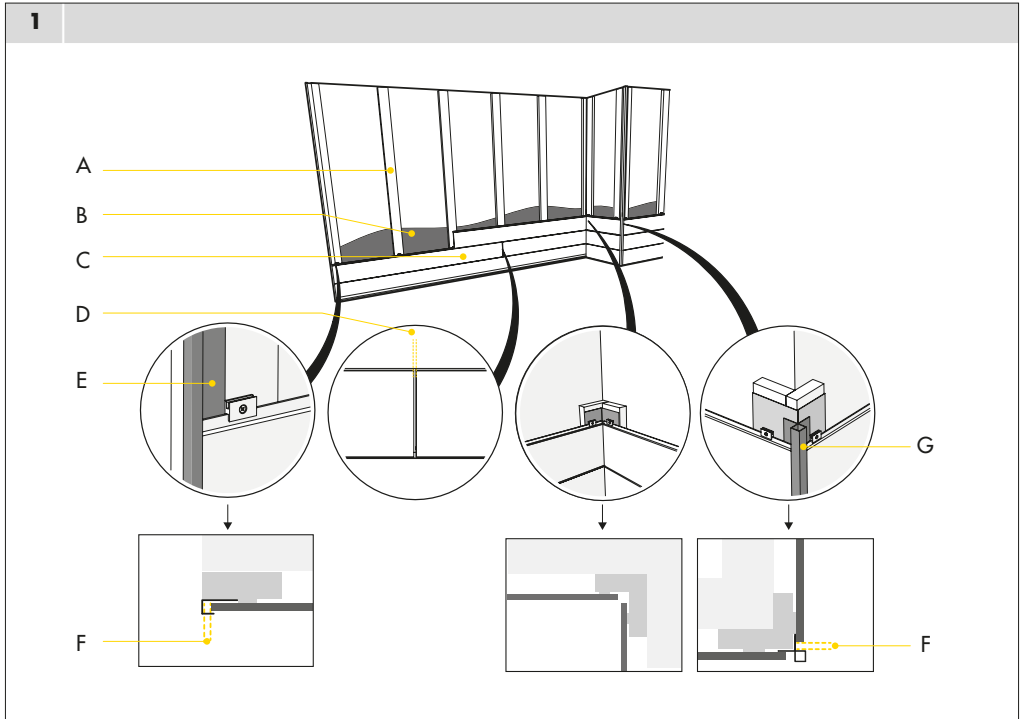

ENGLISH UK

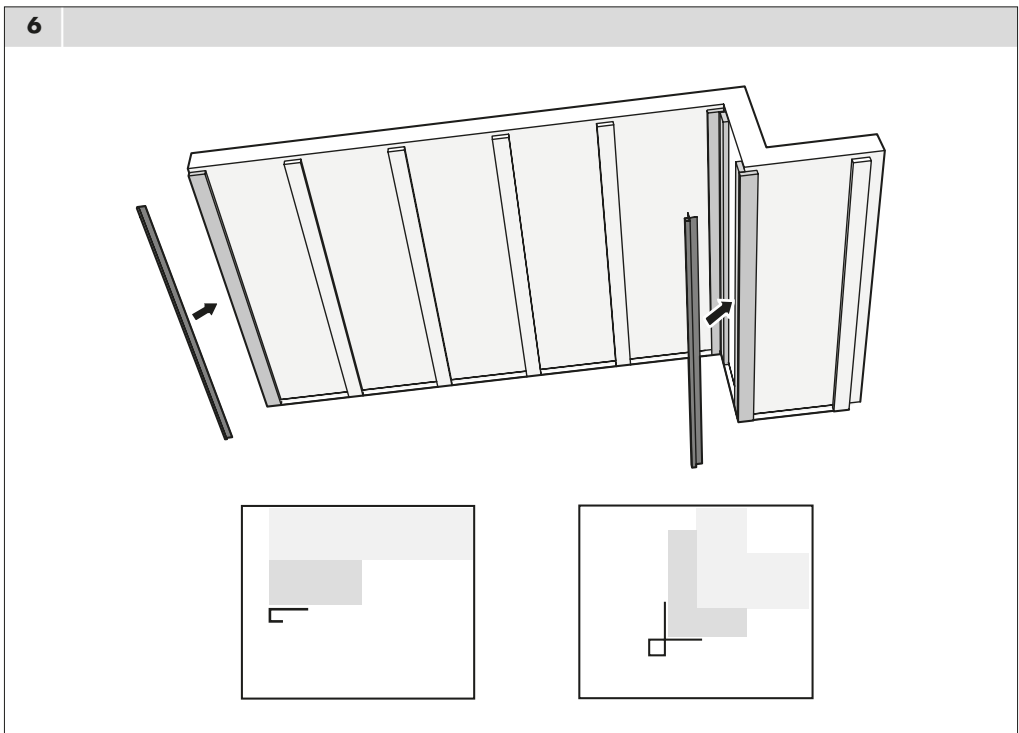
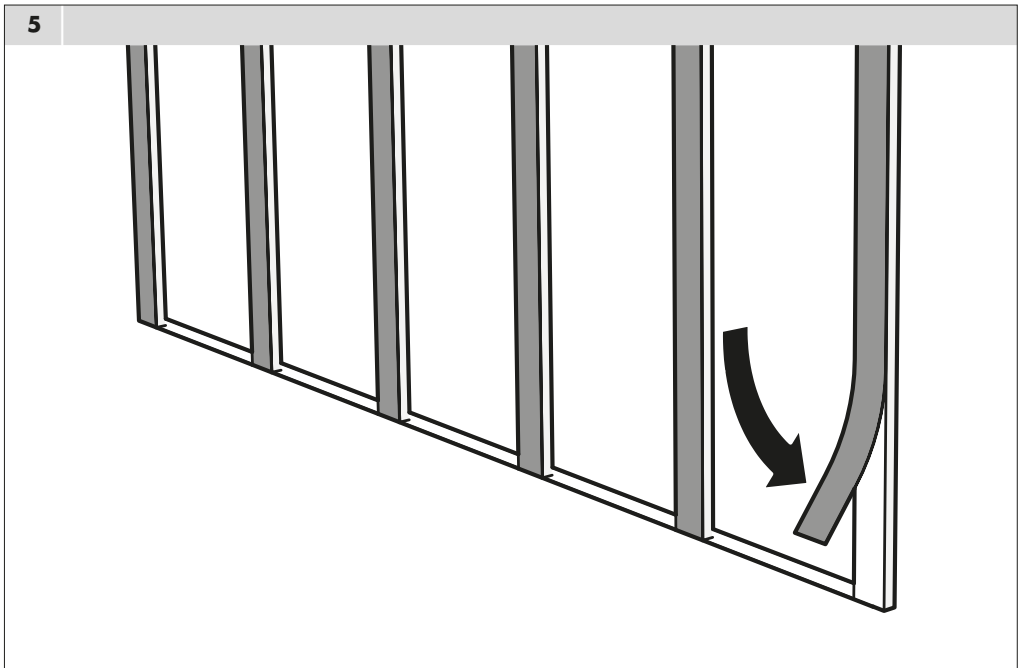
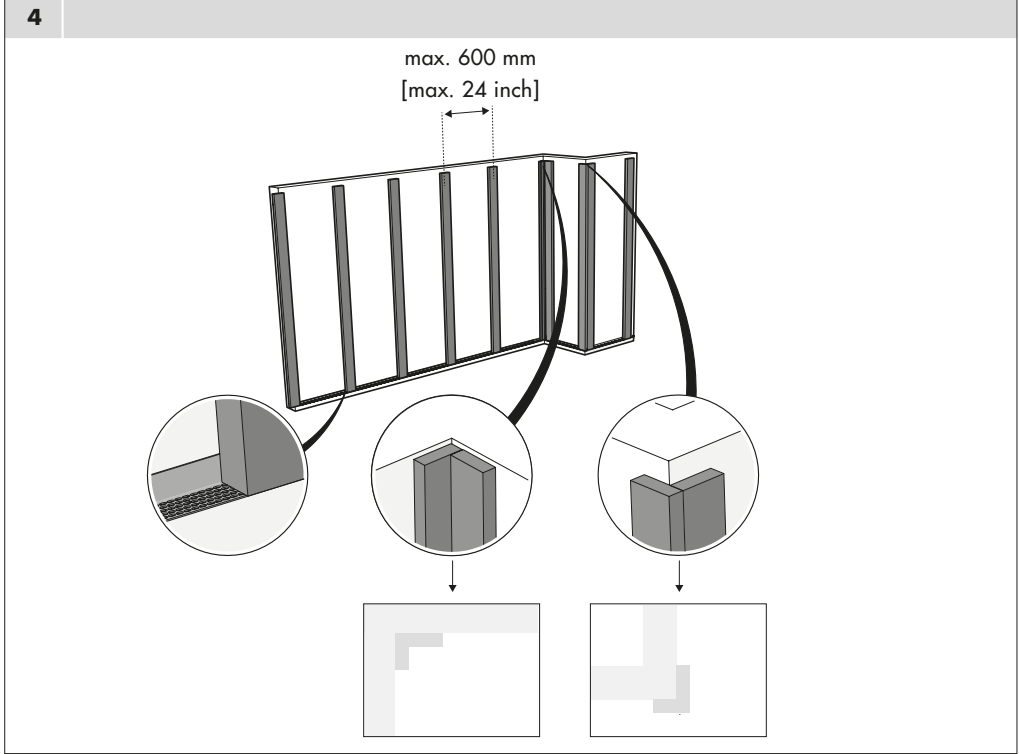

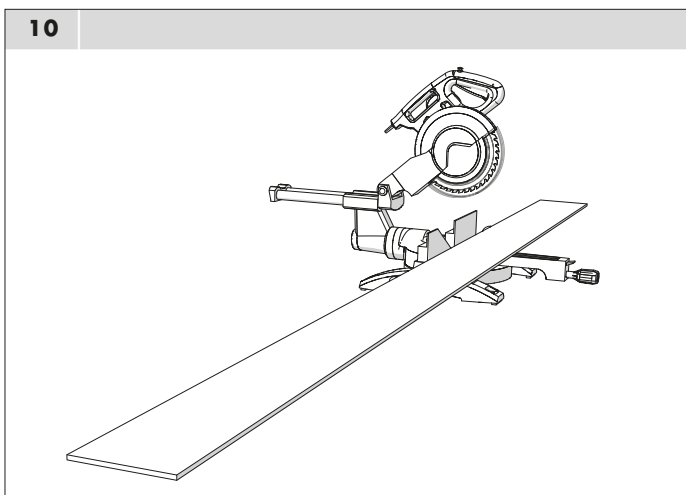
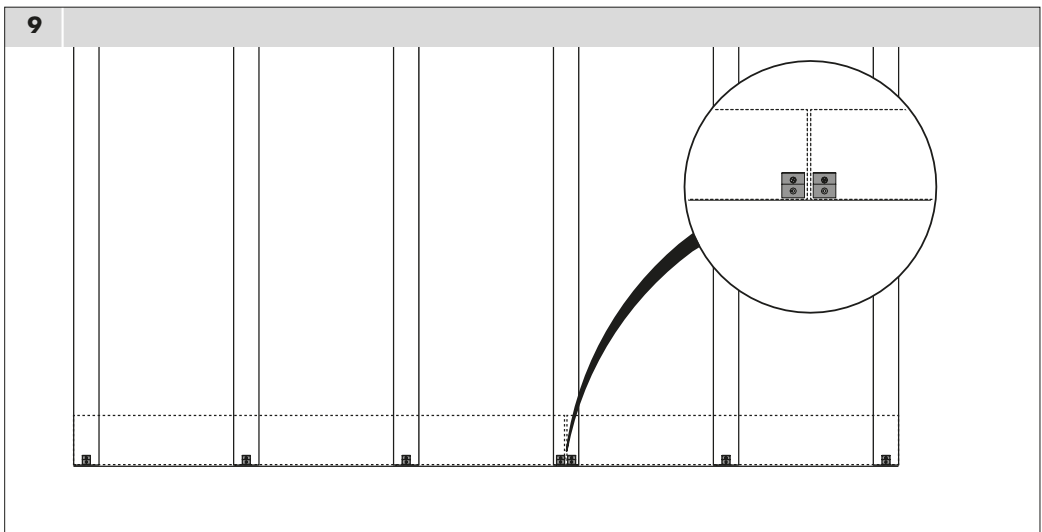
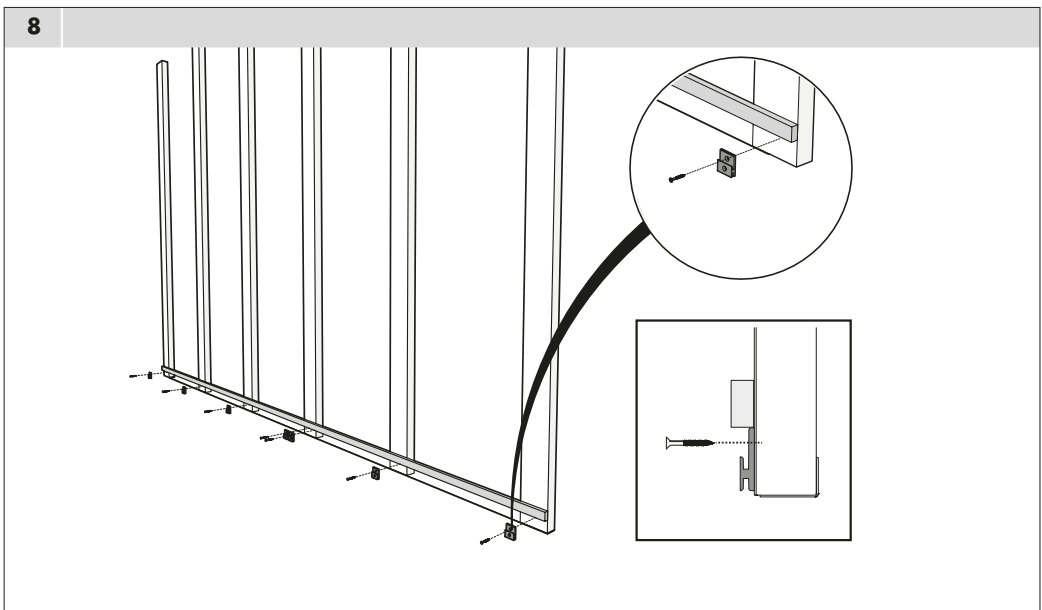
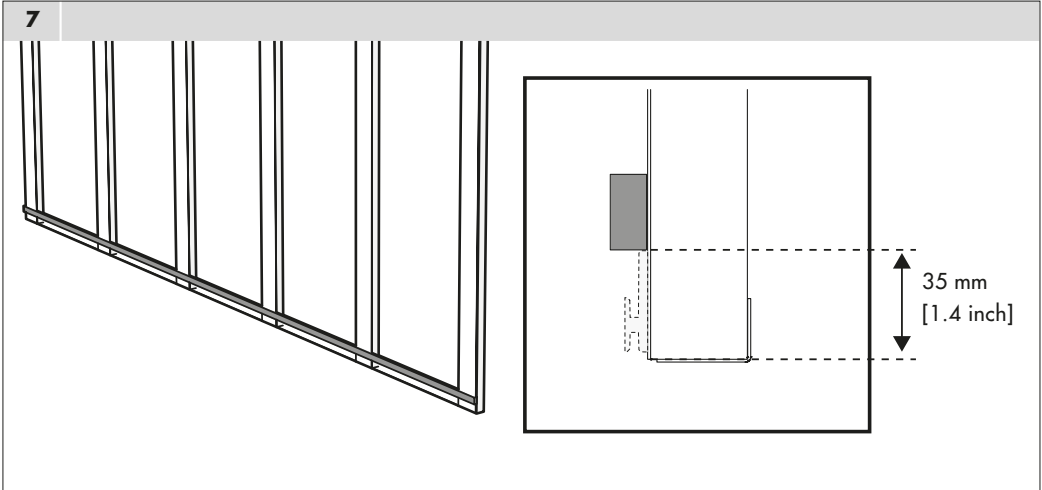

ENGLISH UK

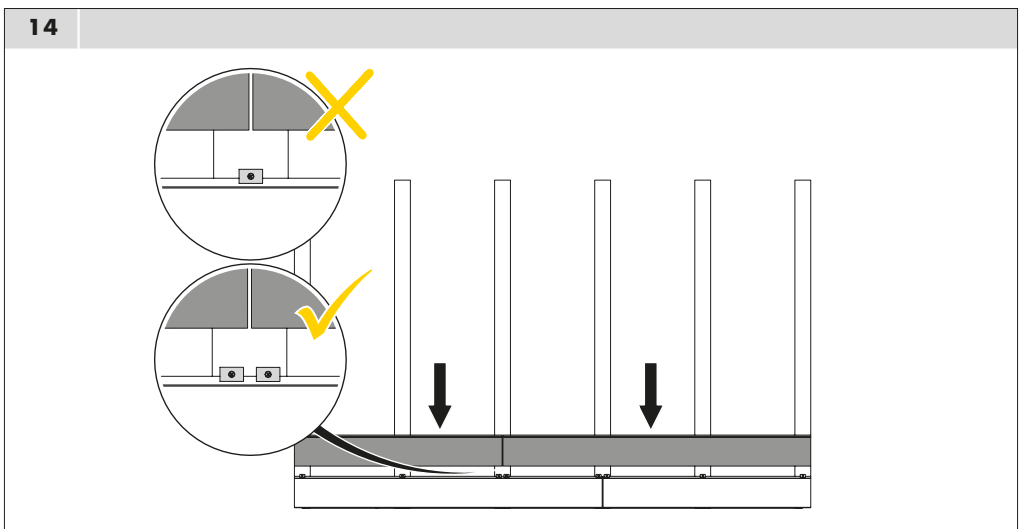
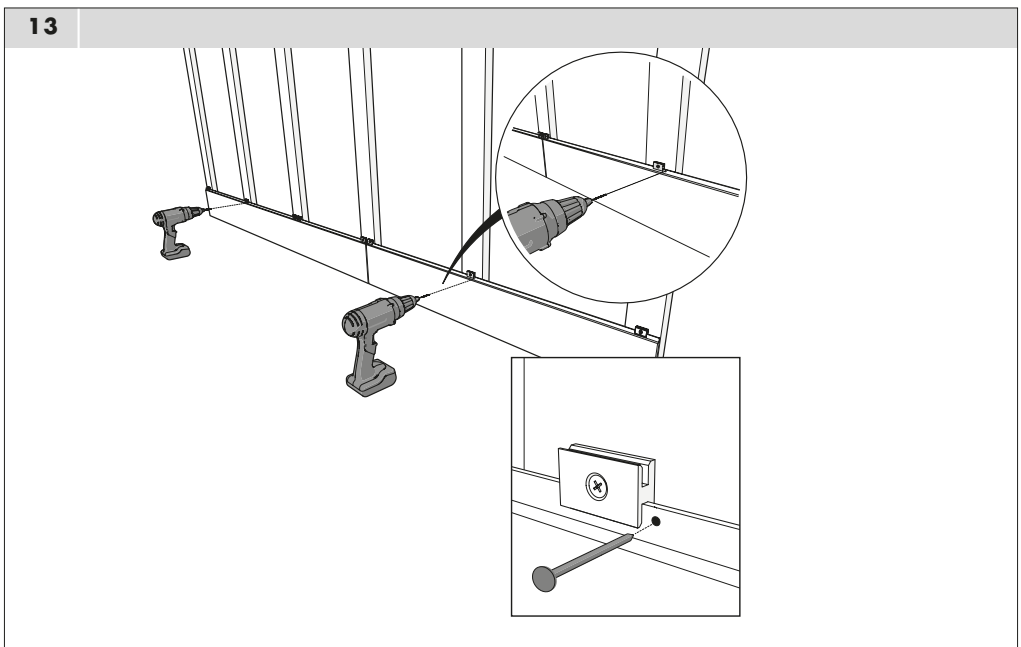
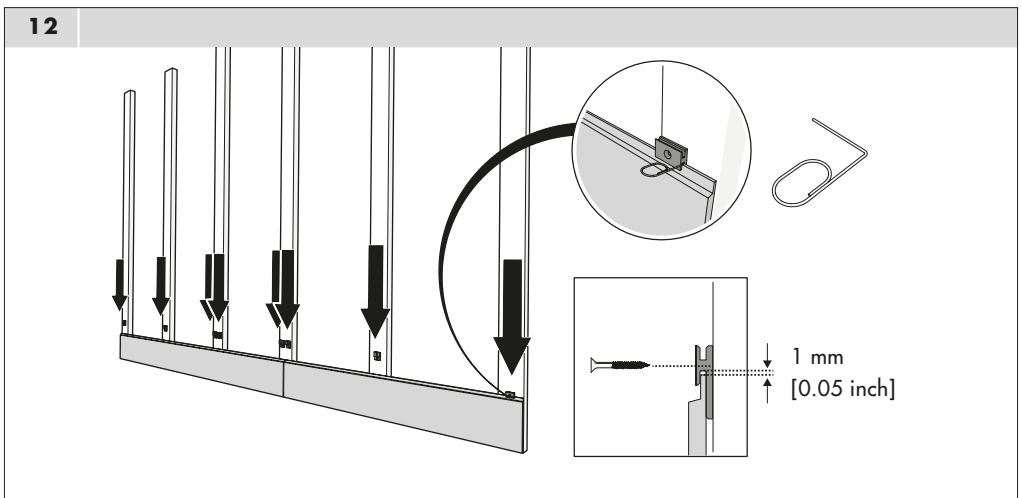
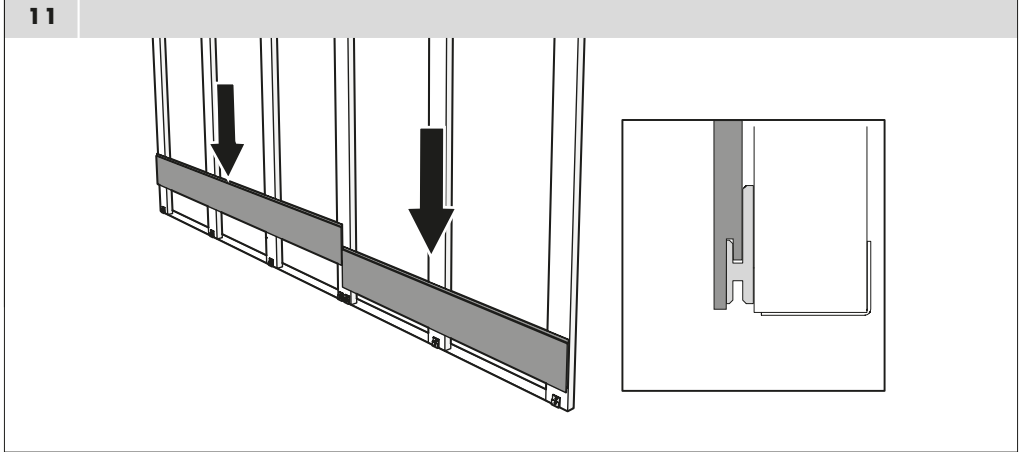

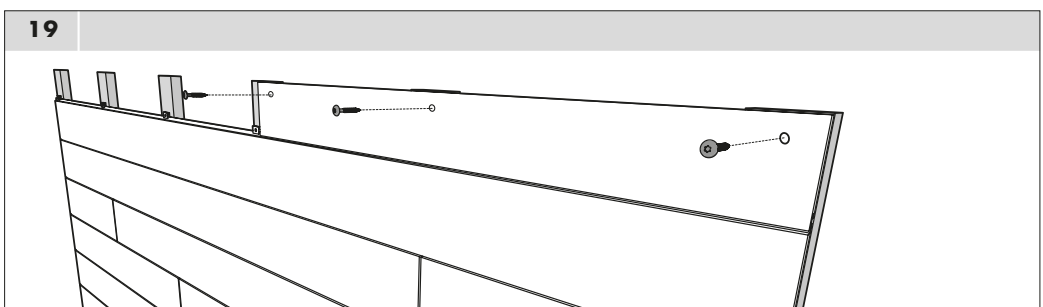
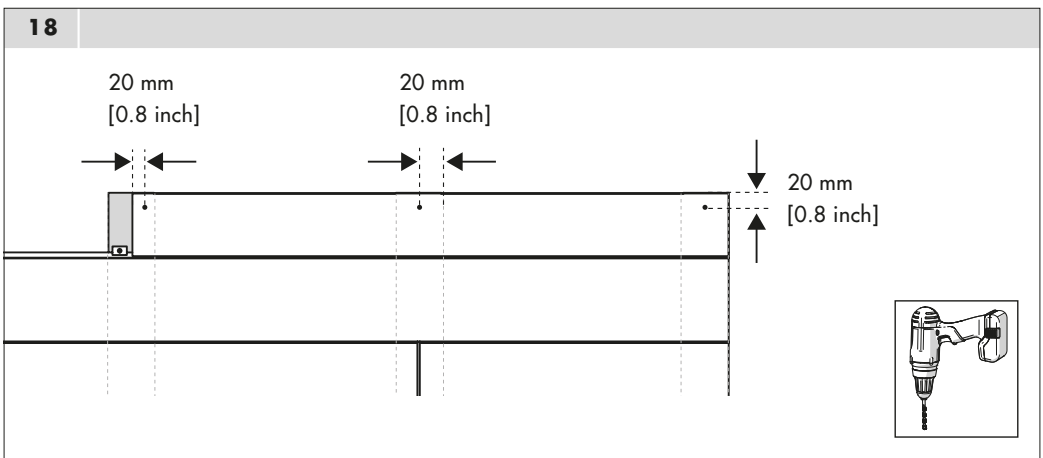
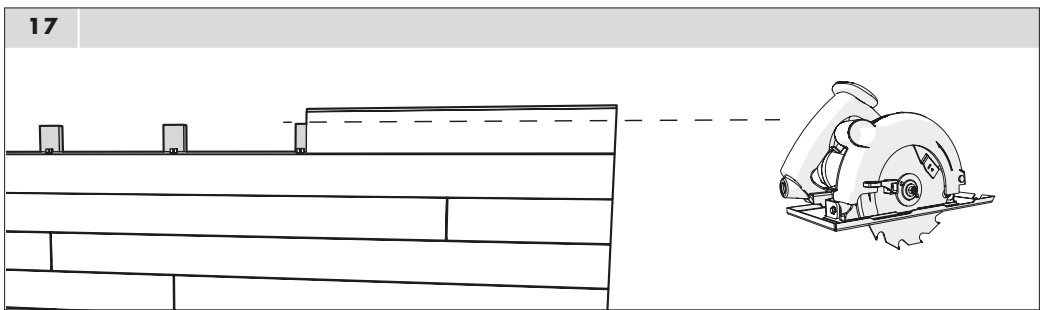
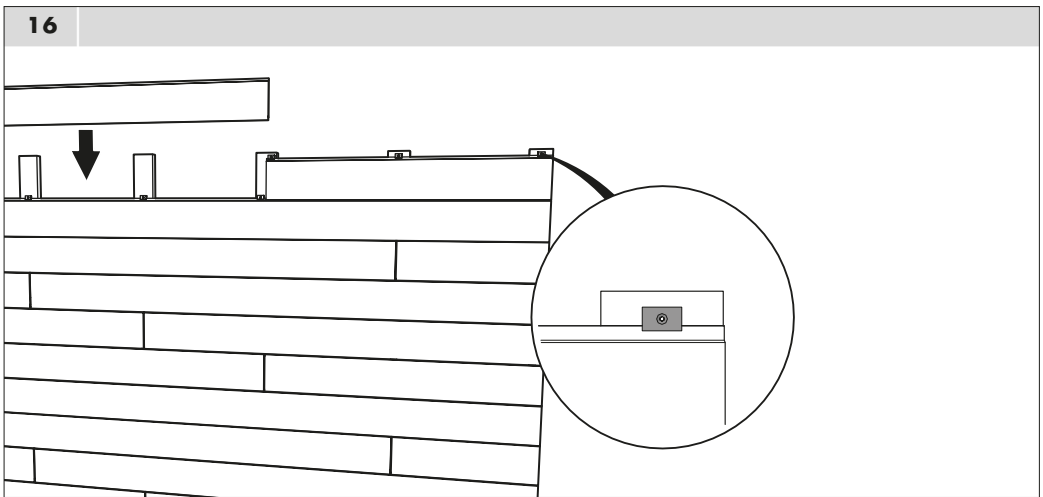
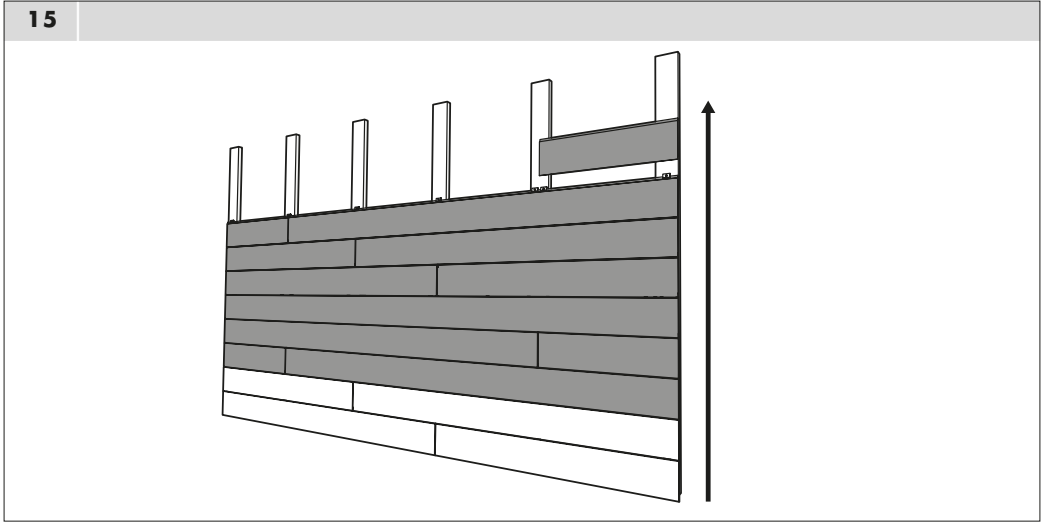

ENGLISH UK

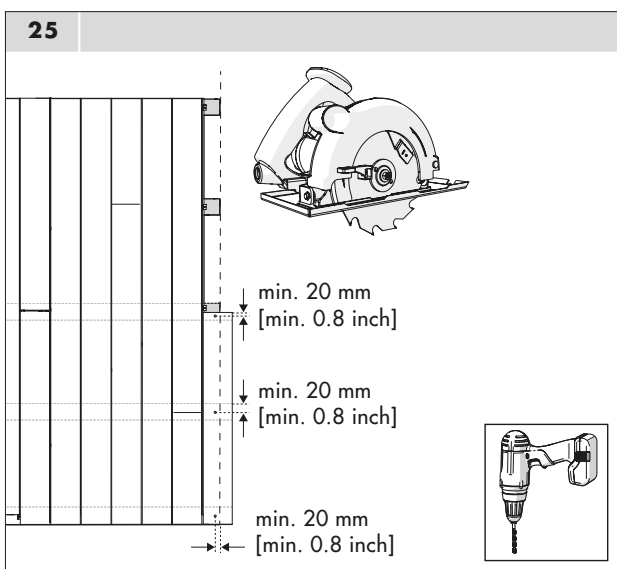
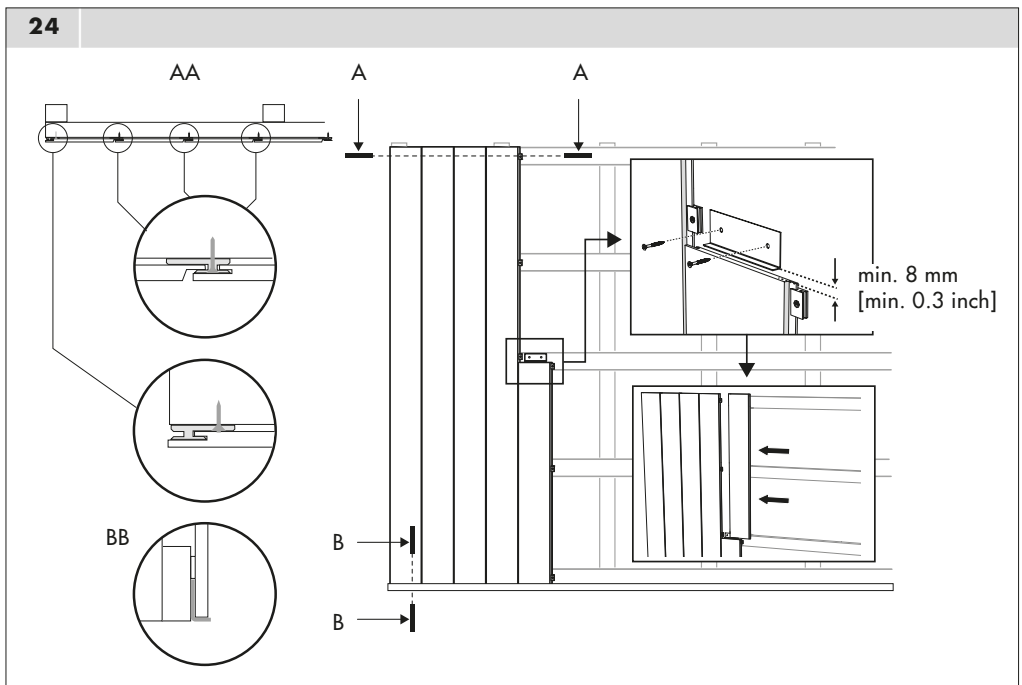
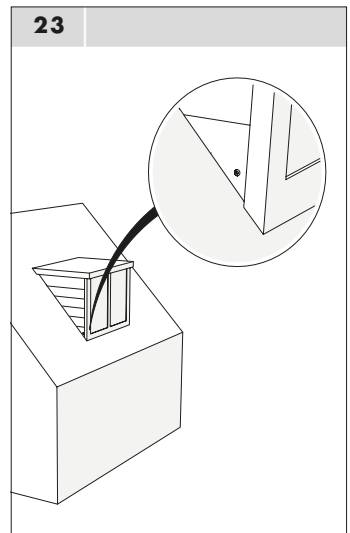
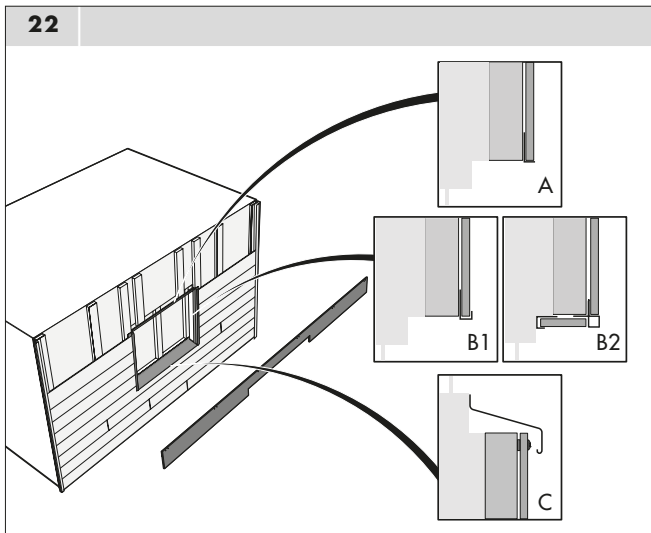
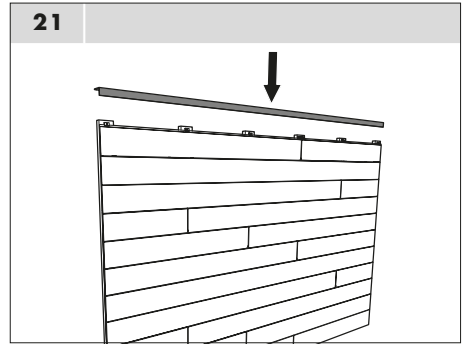
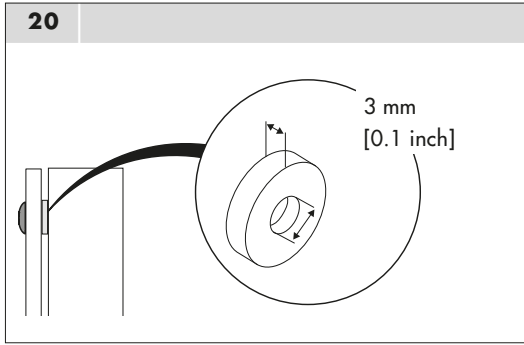

CONTACT US

TRESPA INTERNATIONAL B.V.

P.O. Box 110, 6000 AC Weert
Wetering 20, 6002 SM Weert
The Netherlands
www.trespa.com

CUSTOMER SERVICE DESK EMEA EXPORT

Tel: +31 (0) 495 458 839
Info.Export@Trespa.com

TRESPA UK LTD.

35 Calthorpe Road
Edgbaston
Birmingham, B15 1TS
United Kingdom
Tel: 0808-2340268
Info.UK@Trespa.com

FOLLOW US



PURA-NFC.COM



U1093-432372 ■ VERSION 4.0
BROCHURE CODE U1093
DATE 01-2021

TRESPA®